



Intake/delivery connections 1/4" - flow rate 5 l/min

MIDGETBOX



STANDARD: II 3/3G D IIB T 135°C (zone 2)
 CONDUCT: II 2/2GD c IIB T 135°C (zone 1)

Intake/delivery connections	G 1/4" f
Air connection	G 1/8" f
Max. self-priming capacity*	3 m
Max. flow rate*	5 l/min
Max. head*	70 m
Max. air supply pressure	7 bar
Max. diameter of passing solids (spherical particles)	0 mm

Construction materials	Weight	Max. operating temp.
PP	0,5 Kg	60°C



PP

TECHNICAL DATA

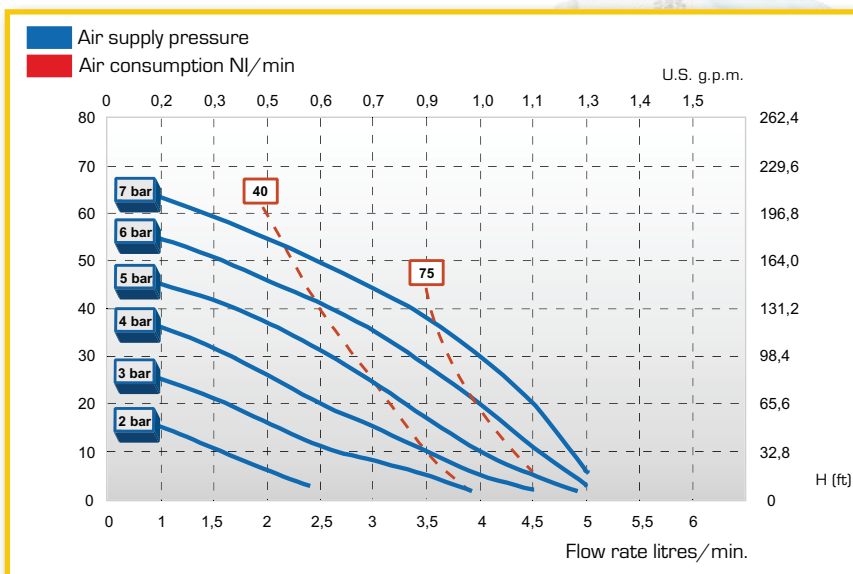

PERFORMANCE

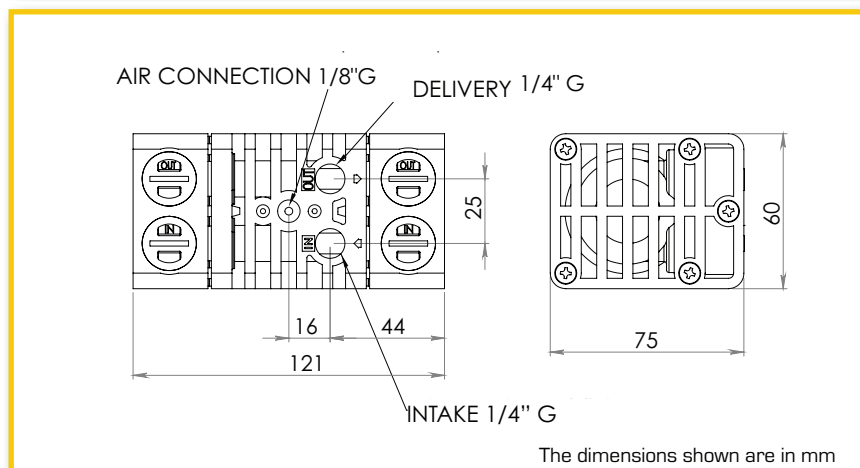

DIMENSIONS

*The curves and performance values refer to pumps with submerged suction and a free delivery outlet with water at 20°C, and vary according to the construction material. All the values shown are approximate and not binding