





 Ghisa EN-GJL-250	 Cast Iron EN-GJL-250
 Fonte EN-GJL-250	 Grauguss EN-GJL-250
 Hierro fundido EN-GJL-250	 Ferro fundido EN-GJL-250

Curva caratteristica - Performance curve - Courbe caractéristique
Kennlinie - Curva característica - Curva característica

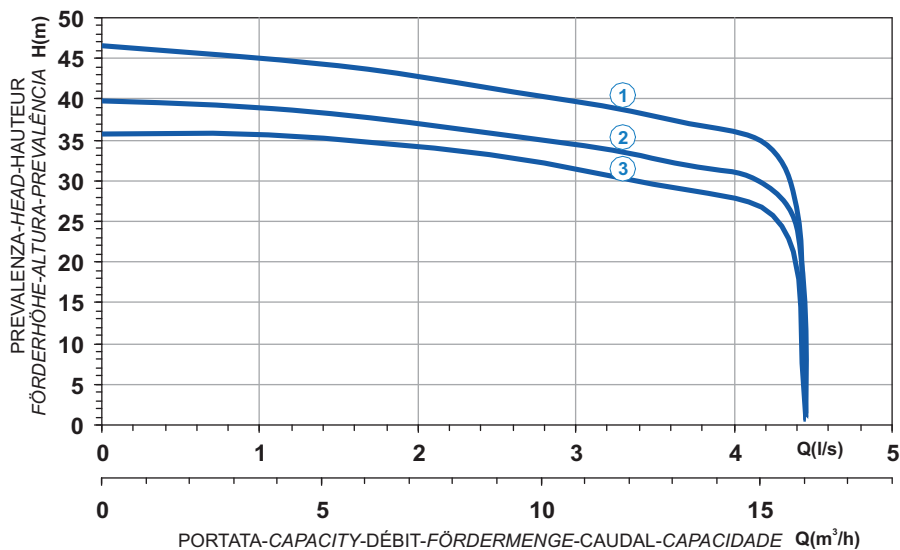

T

Curve N°	Code	Type	MOTOR			ATEX code 
			Nominal power P2 (kW)	Nominal current I (A)	Starting current Is (A)	
1	7001600	G210R6T1-J7AA2	5,0	11	65	7002801
2	7001923	G210R6T2-J7AA2	5,0	11	65	7002802
3	7001924	G210R6T3-J7AA2	4,1	8,5	50,1	7002803

Power supply	3ph 400/690V 50Hz
R.P.M.	2850
Free passage (mm)	7
Discharge (mm)	DN 40
Weight (Kg)	66

Dimensioni - Dimensions - Dimensions - Abmessungen - Dimensiones - Dimensões (mm)

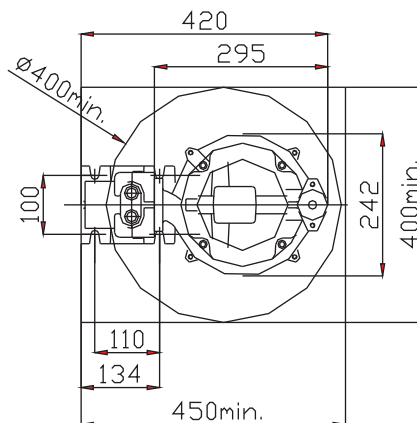
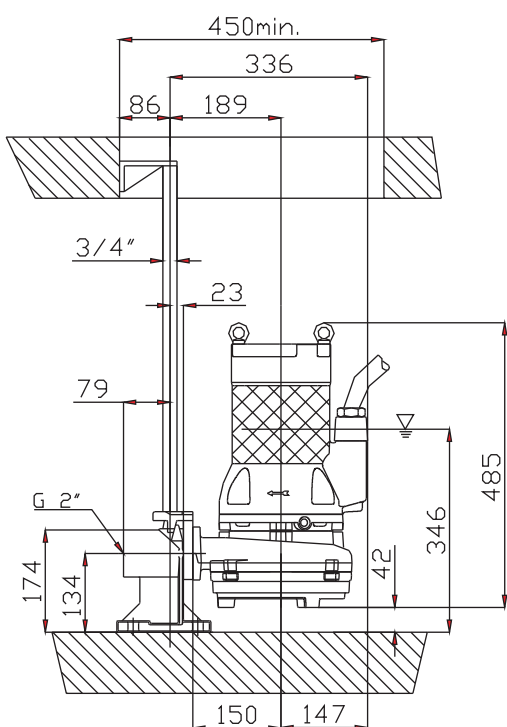

▽ LIVELLO MINIMO DI SOMMERSIBILITÀ
MINIMUM SUBMERSIBLE LEVEL
NIVEAU MINIMUM D'IMMERSION
MINDESTWASSERSTAND
NIVEL SUMERGIBLE MÍNIMO
NÍVEL MÍNIMO DE SUBMERSIBILIDADE

