

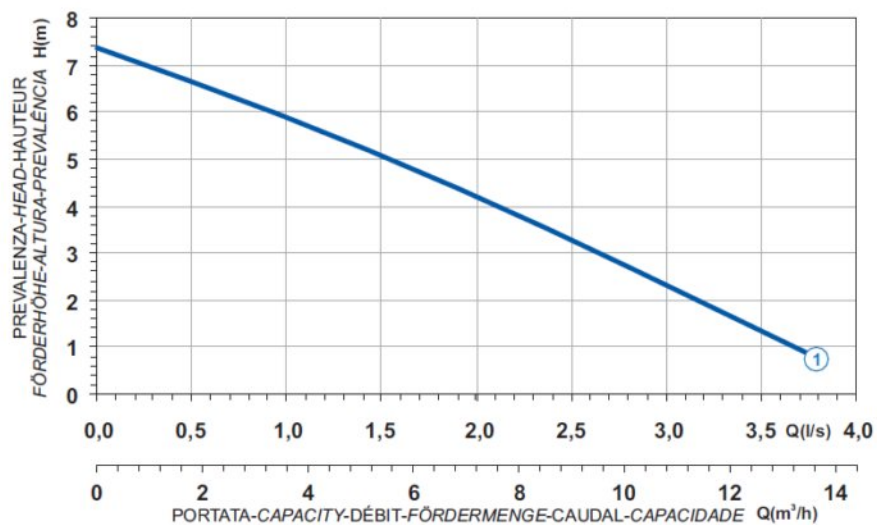

 Ghisa EN-GJL-250
 Fonte EN-GJL-250
 Hierro fundido EN-GJL-250

 Cast Iron EN-GJL-250
 Grauguss EN-GJL-250
 Ferro fundido EN-GJL-250

Curva caratteristica - Performance curve - Courbe caractéristique
 Kennlinie - Curva característica - Curva característica



Curve N°	Code	Type	MOTOR			ATEX code 
			Nominal power P2 (kW)	Nominal current I (A)	Starting current Is (A)	
1	7002139	G206T6V1-D30AA0	0,5	1,5	5,2	-

Power supply	3ph 400V 50Hz
R.P.M.	2850
Free passage (mm)	30
Discharge (mm)	DN 40
Weight (Kg)	13

Dimensioni - Dimensions - Dimensions - Abmessungen - Dimensiones - Dimensões (mm)

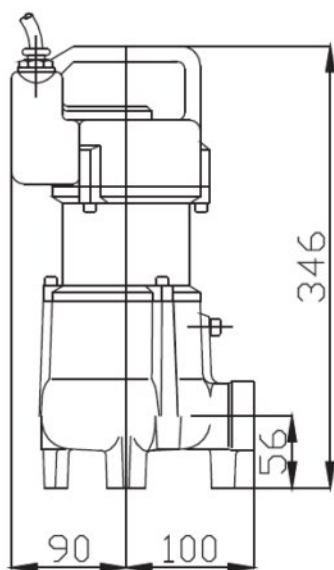

▽ LIVELLO MINIMO SOMMERGIBILITÀ
 MINIMUM SUBMERSIBLE LEVEL
 NIVEAU MINIMUM D'IMMERSION
 MINDESTWASSERSTAND
 MINIMO NÍVEL
 NÍVEL MÍNIMO DE SUBMERGIBILIDADE

