





 Ghisa EN-GJL-250	 Cast Iron EN-GJL-250
 Fonte EN-GJL-250	 Grauguss EN-GJL-250
 Hierro fundido EN-GJL-250	 Ferro fundido EN-GJL-250

Curva caratteristica - Performance curve - Courbe caractéristique
Kennlinie - Curva característica - Curva característica

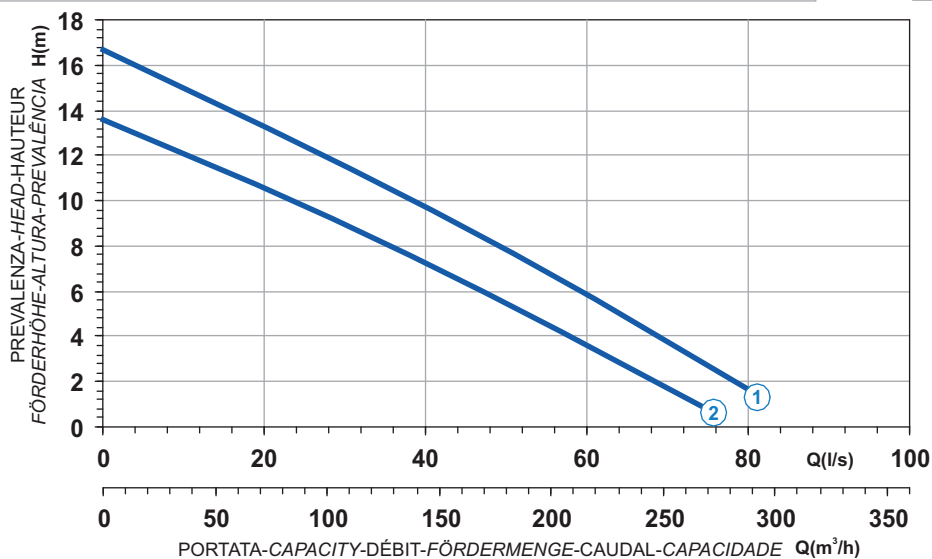

Curve N°	Code	Type	MOTOR			ATEX code 
			Nominal power P2 (kW)	Nominal current I (A)	Starting current Is (A)	
1	7000299	G618R3V1-S100AA2	13,6	27,5	148,5	-
2	7000300	G618R3V2-S100AA2	11,0	23,0	124,2	-

Power supply	3ph 400/690V 50Hz
R.P.M.	950
Free passage (mm)	100
Discharge (mm)	DN 150
Weight (Kg)	361

Dimensioni - Dimensions - Dimensions - Abmessungen - Dimensiones - Dimensões (mm)

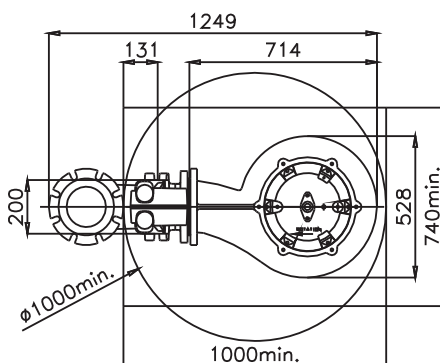
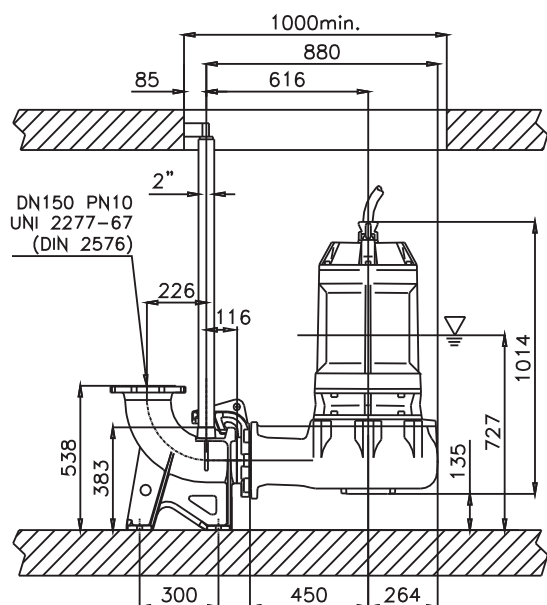

∇ LIVELLO MINIMO SOMMERGIBILTÀ
MINIMUM SUBMERSIBLE LEVEL
∇ NIVEAU MINIMUM D'IMMERSION
MINDESTWASSERSTAND
MINIMO NÍVEL
NÍVEL MÍNIMO DE SUBMERGIBILIDADE

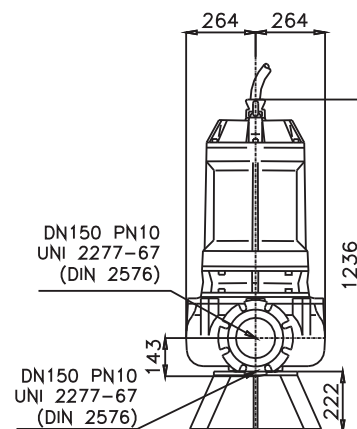

Versione disponibile con mantello di raffreddamento - Type available also with cooling jacket
Version disponible avec chemise de refroidissement - Ausführung auch mit Kühlmantel lieferbar
Disponible también con camisa de refrigeración - Versão disponível com cobertura de arrefecimento