



 Ghisa EN-GJL-250
 Fonte EN-GJL-250
 Hierro fundido EN-GJL-250

 Cast Iron EN-GJL-250
 Grauguss EN-GJL-250
 Ferro fundido EN-GJL-250

Curva caratteristica - Performance curve - Courbe caractéristique
 Kennlinie - Curva característica - Curva característica

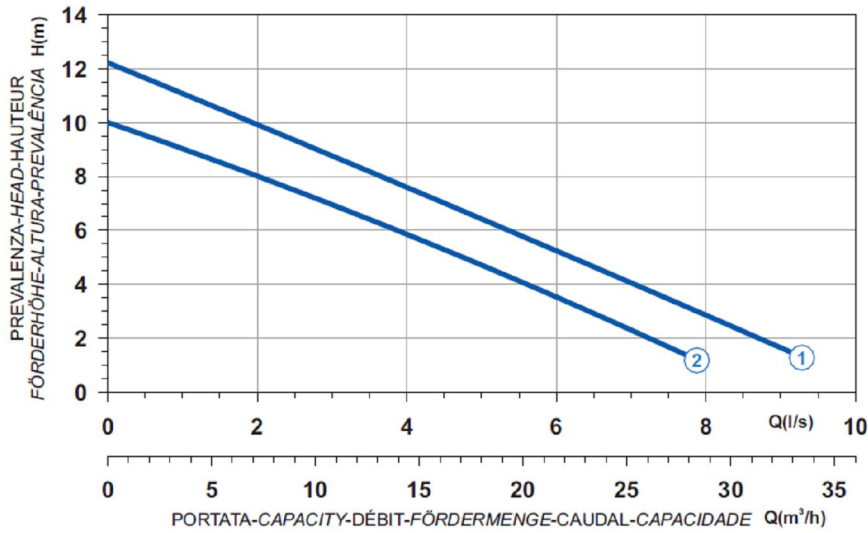

Curve N°	Code	Type	MOTOR			ATEX code 
			Nominal power P2 (kW)	Nominal current I (A)	Starting current Is (A)	
1	7000854	G272T3V1-K48AA0	1,4	3,0	8,4	-
2	7009010	G272T3V2-K48AA0	1,4	3,0	8,4	-

Power supply	3ph 400V 50Hz
R.P.M.	2850
Free passage (mm)	48
Discharge (mm)	DN 50
Weight (Kg)	31

Dimensioni - Dimensions - Dimensions - Abmessungen - Dimensiones - Dimensões (mm)

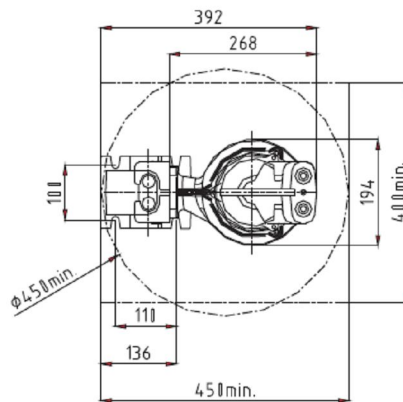
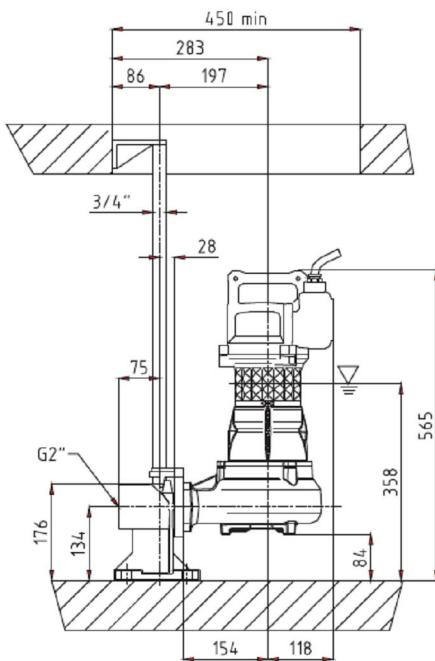

▽ LIVELLO MINIMO SOMMERGIBILTÀ
 MINIMUM SUBMERSIBLE LEVEL
 NIVEAU MINIMUM D'IMMERSION
 MINDESTWASSERSTAND
 MINIMO NIVEL
 NÍVEL MÍNIMO DE SUBMERGIBILIDADE

